

Instruction Manual	pag. 02	EN
Bedienungsanleitung	Seite 27	DE
Manual de Instrucciones	Página 52	ES
Manuel d'utilisation	page 77	FR
Manuale d'Uso	pagina 102	IT
Használati útmutató	127. oldal	HU
Instrukcja obsługi	strona 152	PL
Инструкция по эксплуатации	стр. 177	RU
Uputstvo za upotrebu	str. 202	SR
Інструкція з експлуатації	стр. 227	UK
كتيب التعليمات	صفحة. 01	AR

AQUEENAPRO: WATER PURIFIER

Thank you for choosing ZEPTEK AqueenaPro water purifying system and your trust in Zepter International. Your AqueenaPro will reliably provide clean, healthy and great-tasting water for you and your family. Place Zepter AqueenaPro in your home and enjoy an endless source of pure spring water, every day. Zepter International is a global specialist in health and lifestyle.

This guideline will help you get the best out of your water filtration system. Please go through this user instruction manual to familiarise with its operation and maintenance.

To make sure the warranty is effective, follow all instructions provided in this user manual. For further information or support, please contact your Zepter sales representative*.

For any questions regarding AqueenaPro installation, maintenance or filter replacement, please contact your service technician/Zepter Service Centre*.

*All contact details can be found in the Warranty card.

INTRODUCTION	02
CONTENT	03
SAFETY INFORMATION	04
AQUEENAPRO TECHNOLOGY	10
AQUEENAPRO FEATURES	10
AQUEENAPRO OVERVIEW	11
ITEMS IN THE BOX	12
AQUEENAPRO INSTALLATION	12
– Installation Instructions	13
OPERATING INSTRUCTION	13
– Before first use	13
– RO Membrane Installation	14
– Display functions	15
MAINTENANCE AND FILTER REPLACEMENT METHOD	16
– Flushing the RO Membrane	16
– Filter Replacement Method	16
– Filters replacement procedure	16
– Restoring leakage sensor	17
– After filter replacement	18
– The RO replacement procedure	19
– Filter Replacement Time	19
– RO membrane replacement time	20
TECHNICAL INFORMATION	21
OPERATING INFORMATION	21
TROUBLESHOOTING GUIDELINE	22
DISPOSAL INFORMATION	23
WARRANTY CARD	24
WARRANTY STATEMENT	25
AQUEENAPRO PERFORMANCE DATA SHEET	26

The manual uses specifications to draw your attention to some details



Warning! Failure to observe a warning may result in severe physical injury or property damage



Caution! For safety reasons, be careful! Failure to observe a caution sign may result in minor physical injury or property damage



Note! It contains additional information and useful advice for the proper use of the water filtration unit.



Caution!

- This user manual is an integral part of the appliance. Read all the instructions and safety precautions contained in this manual carefully, as they provide important information on the use and maintenance of the device. Keep the manual for future reference.
- After removing the packaging, make sure that the water filtration unit is intact, carefully inspect the device body and the accessory box.
- This appliance should only be used for its intended purpose. The manufacturer shall not be held liable for any damages caused by improper, incorrect or unreasonable use.

- This appliance is not intended for use by persons (including children) with reduced physical, sensory or mental capabilities, or lack of experience and knowledge, unless they are supervised or have been instructed on the use of the appliance by a person responsible for their safety.
- Children should be supervised to ensure that they do not play with the appliance.
- At the end of its lifetime, the appliance should be disposed of separately from ordinary waste, leaving it with operators who are qualified to collect this kind of material. In this way it will be properly disposed of and recycled, helping to safeguard the environment!

**Note!**

1. AqueenaPro is a water filtration system for household use. Any use outside your home and for purposes other than purifying water for household use will automatically void your warranty.
2. The AqueenaPro should not be used on feed water that is microbiologically unsafe or has unknown microbiological quality without disinfecting the water before using the device.

- 3. Cold water plumbing** – AqueenaPro must be connected to a cold water pipe. Using hot water ($>38^{\circ}\text{C}$) as a water source will cause permanent damage to the RO membrane and severely degrade the performance of the product.



Warning!

Important safety information:

Warning for the European market:

This appliance can be used by children aged over 8 years and persons with reduced physical, sensory or mental capabilities or lack of experience and knowledge if they are supervised or have been instructed on the safe use of the appliance and understand the hazards involved. Children shall not play with the appliance. Cleaning and user maintenance shall not be carried out by children without supervision

Warning for Non-European markets:

This appliance is not intended for use by persons (including children) with reduced physical, sensory or mental capabilities, or lack of experience and knowledge, unless they are supervised or have been instructed on the use of the appliance by a person responsible for their safety.

Children should be supervised to ensure that they do not play with the appliance. The new hose-sets supplied with the appliance are to be used and old hose-sets should not be reused.

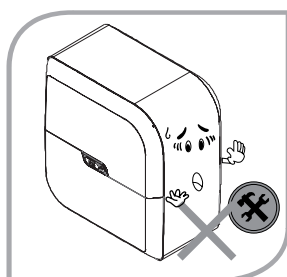

- **Do not disassemble or modify AqueenaPro on your own!**

Never attempt to repair or change any internal part of AqueenaPro, as it may compromise the efficiency and safe operation of your water purifier. Any unauthorised change will automatically void the warranty. If you find that a repair is needed, please contact your Zepter service technician for support.

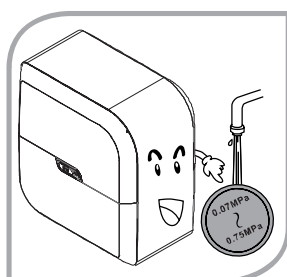

- **Do not use AqueenaPro under high water pressure!**

Operating under high pressure conditions may result in rupture of the water purifier pipes and a consequent water leakage. Recommended inlet pressure is 0.1MPa to 0.35MPa. (14.5 - 50.8 psi).

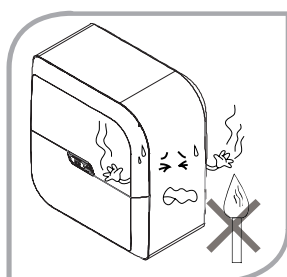

- **Do not use AqueenaPro near gas, naked flames, explosive or highly flammable materials.**

Do not leave the water purifier near fireplaces or other high temperature heat sources (stove, oven), as it can result in deformation or melting of the housing.

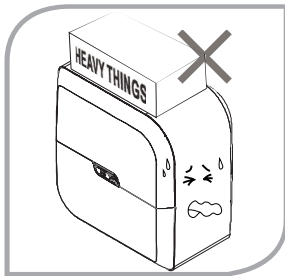

- **AqueenaPro is a free-standing unit.**

Do not place or keep anything on top of the unit.

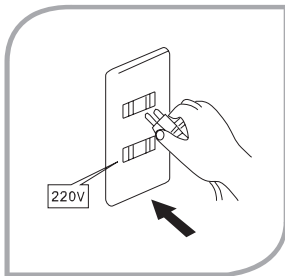

- **Before connecting the unit to the mains,** make sure the information found on the data plate matches that of your electricity mains.

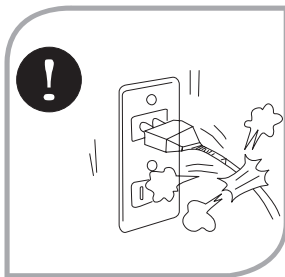

- **Do not use the appliance if the power cord or plug are damaged.**

If the supply cord is damaged, it must be replaced by the manufacturer, its service agent or similarly qualified persons in order to avoid a hazard. The appliance is only to be used with the power supply unit provided with the water dispenser.

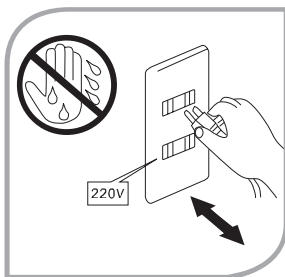

- **Do not touch the power plug with wet hands!**

It may lead to electric shock.

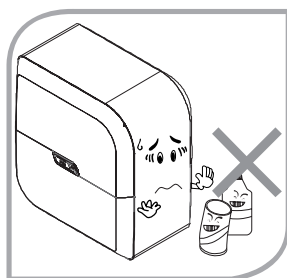

Caution!

- **Do not use any chemicals when cleaning the outside casing of AqueenaPro.**

Alcohol, petrol, organic and inorganic acids and strong basic chemicals like concentrated dishwashing detergents will irreparably damage the plastic housing of your AqueenaPro.

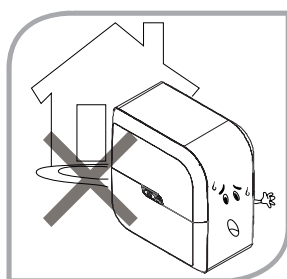

- **Do not use your AqueenaPro outdoors!**

Using AqueenaPro outdoors can accelerate the corrosion of pipes and parts, which can result in leaks or damage to the device.

AQUEENAPRO TECHNOLOGY

AqueenaPro is a low-noise 5-stage filtration system which uses the most advanced international RO (reverse osmosis) technology currently available.

The heart of the AqueenaPro water filtration system is a RO membrane with 0.0001-micron small pores designed to remove even dissolved impurities (heavy metals), pesticide residues as well as harmful micro organisms (bacteria and viruses). AqueenaPro significantly reduces bacteria and infectious viruses.

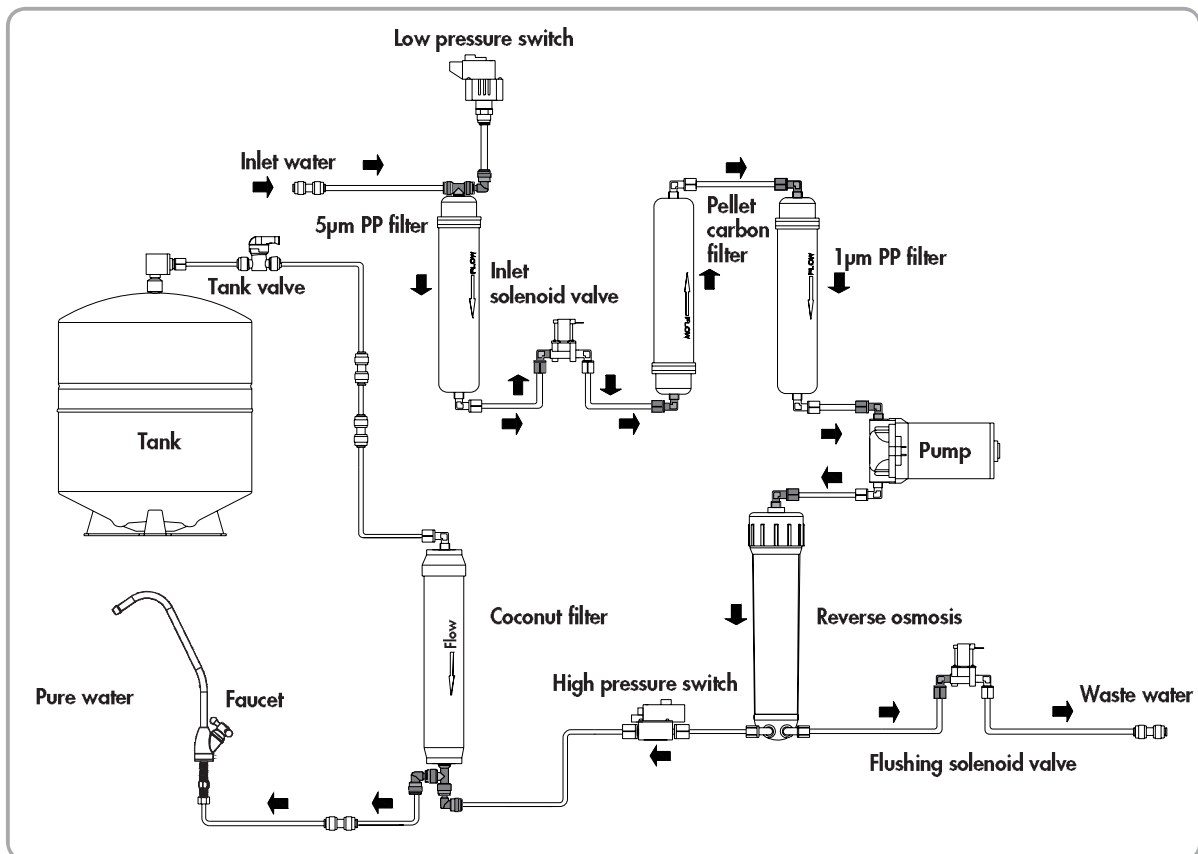

AQUEENAPRO FEATURES

- **Built-in water tank**, theoretical volume 2.5 Gallon (9.5 l).
- **Computer control box**, which automatically adjusts AqueenaPro's working status.
- **Filter change alarm**, which indicates when the filter needs to be replaced.
- RO membrane integrated with the membrane housing to prevent tampering.
- **Leakage sensor**, to detect device leakage; it secures the user's property and avoids damages caused by leaks.
- **High pressure pump**, which creates a stable environment for the RO membrane.
- **Flushing solenoid valve**, to flush the RO membrane automatically and control waste water flow.
- **Inlet solenoid valve**, which by definition opens or shuts inlet water pressure in a range between 0.03 and 0.6MPa (4.35 – 87 psi).
- **Checking flow valve**, to prevent water backflow.
- **Safe feature**, pressure switch.

AQUEENAPRO OVERVIEW

EN

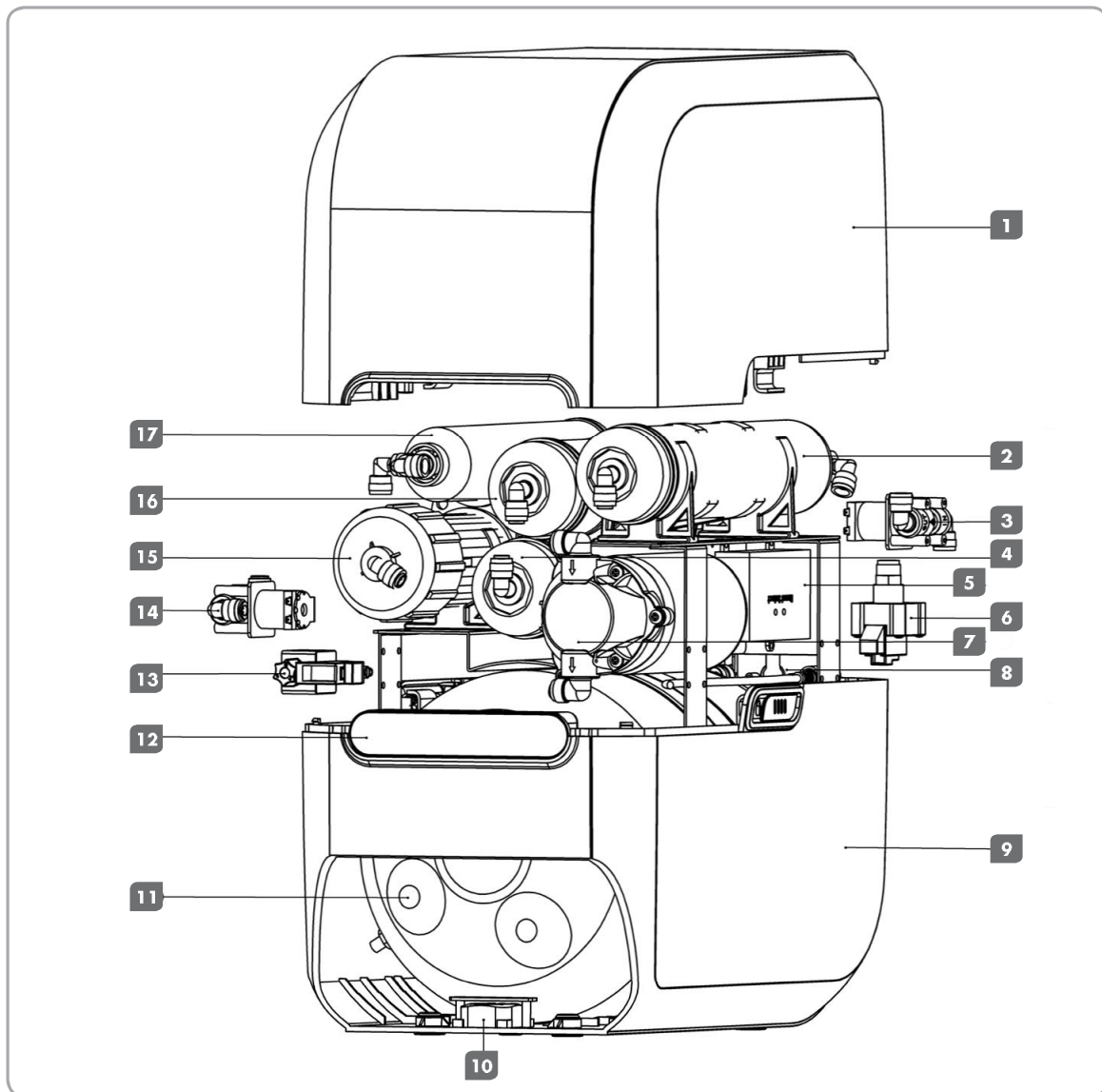

- | | |
|--|------------------------------------|
| 1. Upper cover | 10. Leakage sensor |
| 2. 5 micron PP Filter | 11. 2.5G water tank |
| 3. Inlet Solenoid Valve | 12. Display |
| 4. Pellet Carbon Filter | 13. High pressure switch |
| 5. Computer control box | 14. Flushing Solenoid Valve |
| 6. Low Pressure Switch | 15. Reverse Osmosis |
| 7. Pump | 16. 1 micron PP Filter |
| 8. Bracket for inlet/outlet water | 17. Coconut Filter |
| 9. Lower cover | |

ITEMS IN THE BOX

1. AqueenaPro water filtration system	1 piece
2. RO membrane in protective film	1 piece
3. Power supply adaptor	1 piece
4. User manual	1 piece
5. Drinking water faucet	1 piece
6. Tube	5 m
7. Drainage clamp	1 piece
8. Wrench for membrane housing	1 piece
9. Accessory bag	1 piece
a) Inline feed water connector	1 piece
b) Clip for quick connectors	2 pieces
c) Faucet fixture	1 piece

AQUEENAPRO INSTALLATION

Installation, servicing, maintenance and repairs should only be performed by Zepter authorised staff.

All maintenance should be performed using original Zepter replacement cartridges and spare parts.

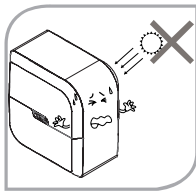

Warning!

- **Avoid exposure to direct sunlight and installation in damp areas**

It may create a breeding ground for microorganisms resulting in reduced purified water quality, as the internal components of the water purifier can be polluted

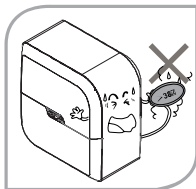

- **Inlet water cannot exceed 38°!**

Using a hot water source (>38°C) will cause permanent damages to the RO membrane and severely degrade the performance of the product.

Make sure that AqueenaPro is connected to a cold water supply only.

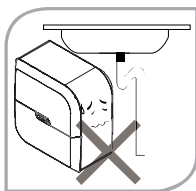

- The maximum distance between the water source and the purifier should not be more than 3 m.
- Avoid sharp bends in the pipe. Do not bend or block the reject water tube.
- Do not confine your AqueenaPro in a tight cabinet.
- Do not use the AqueenaPro when the drain is clogged up.

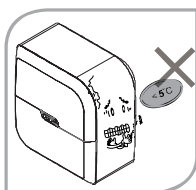

- **Do not use AqueenaPro at temperatures below 5°!**

If the room temperature is below 5°, it can result in pipes cracking due to water freezing inside the machine.

Installation Instruction



Note!

Aqueena Pro water purifier has been designed to be installed under the sink. The initial installation requires carpentry and plumbing works.

Installation, servicing, maintenance and repairs should only be performed by Zepter authorised staff .

Recommended side preparation

- Mains connection no more than 1.5 m from the point of installation of AqueenaPro
- Water supply no more than 3 m away
- Drain for rejected water no more than 3 m away
- Space as per the size of AqueenaPro
- It is preferable to install AqueenaPro near a sink so that inlet and reject water lines are easily available.



Important notes!

1. If you are not using your AqueenaPro for more than two days (48 hrs), switch off the device and drain the storage tank.
2. To keep the storage tank clean, it should be drained once every 2 days.
3. The buzzer will sound to indicate a fault in the purifier. If you hear an audible alarm, take action as reported in the "**Display function**" section and/or the "**Troubleshooting guideline**" or call a service technician for support.
4. Do not try to service the AqueenaPro on your own. Call a service technician/Zepter Service centre for help.

OPERATING INSTRUCTIONS

Before first use

1. Install the RO membrane according to the section **RO Membrane Installation**
2. Make sure that all connections are secure.
3. Connect the water purifier to the mains. Make sure the power connector plug can plug into the local power socket.
4. Bypass the water tank, close the water tank valve.
5. Open water inlet valve and water faucet
6. Switch on your AqueenaPro. As a start up audio signal will be activated 1 buzz.
7. Let water run through the system for approx. 5-10 min (system stabilisation) and check all connections.



Caution! If you find any leaks, do not proceed further until the leaks are fixed.

8. Turn off the water faucet and check if the flow of waste water stops (approx. after 30 s).
9. If no deviation or leak is found, open the water tank valve and let the system fill with water.
10. Drain the first two water tanks before use.



Note! The first two tanks can contain black residues. These are carbon particles washing away from the carbon filter and will not affect future system performance nor the quality of purified water.

11. Measure TDS level and record it on your **Product Warranty Card**.

RO Membrane Installation



Note!

- The AqueenaPro water purifier is delivered with the RO membrane uninstalled and packed separately with protective film.
- In order to prevent microbial contamination of membrane components during storage and transportation, the RO membrane package contains a small amount of protective solution.

1. Remove the AqueenaPro top cover.
2. Unscrew the cap's nut from the membrane housing and remove inlet water pipe.
3. Disassemble membrane cap with the enclosed wrench.
4. Remove RO membrane from its protective film.
5. Insert RO membrane into membrane housing. The membrane end with O-ring must be placed on the bottom of the housing. (see picture below)

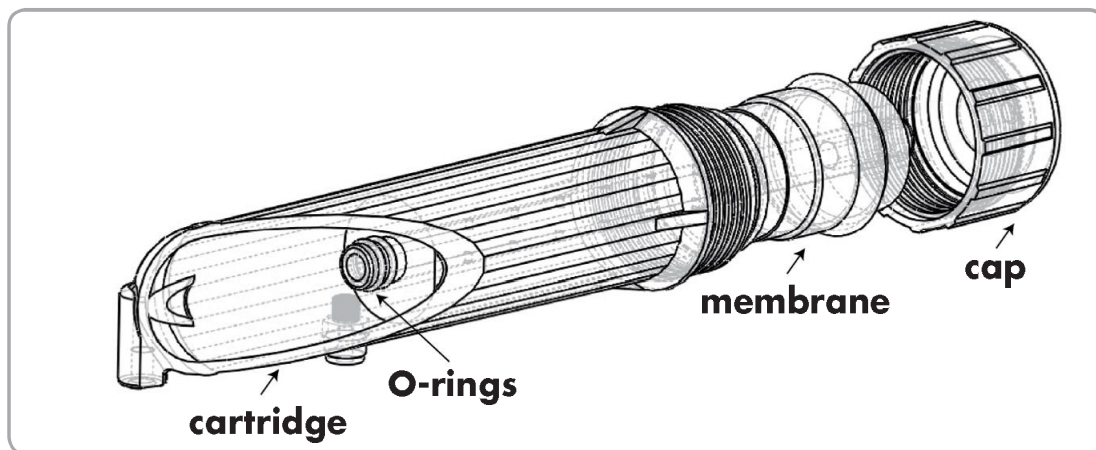

6. Close the membrane casing with the cap. Use the wrench to tighten the cap properly.
7. Connect the inlet water pipe and secure it with the cap's nut.
8. Place the RO membrane cartridge in the correct position.
9. Check all connections and make sure that there are no leaks.
10. Close the AqueenaPro top cover.



Warning!

Pay attention to the direction of the membrane; the membrane ending with an O-ring must be placed in the bottom part of the housing.

- Do not force the RO membrane into the membrane casing; it may cause permanent damage to the membrane shell or membrane components.
- If the RO membrane is installed correctly in the membrane housing, there is no need to force it.

Display functions



If a display icon lights up:



Working: Water purification is in the progress, the device is in working mode.



Water Source: Flashing light - missing inlet water source or low inlet water pressure. The "Water source" icon will light up with an audible alarm (7 buzzes).



Standby: The water purifier is in standby mode.



Flush: The flushing function is activated.



Note! If any leaks occur, all icons ("Working", "Water source", "Standby" and "Flush" icons) will flash at same time along with an audible alarm.



Filter Status Display: It shows the actual filter status.

Green light – the filter works at its optimum level.

Orange light - the filter will soon need replacing. Please contact Zepter Service for maintenance support.

A red light along with an audible alarm (4 buzzes) means that the filter must be changed immediately. Further use of the filter is not recommended.



5 - micron PP filter WT-100-72

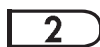

Pellet carbon filter WT-100-73

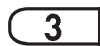

1 - micron PP filter WT-100-74



Coconut filter WT-100-75

Flushing the RO Membrane

The RO membrane is automatically flushed for 18 seconds when the device is turned on. When the water tank is full, the RO membrane is automatically flushed for 10 seconds.

Filter Replacement Method



Note! Filters and membranes are consumables. Their replacement time depends on the quality of raw water and water consumption.

They are not covered by the warranty.

Filter Replacement procedure

1. Turn off the power supply.
2. Close the inlet water valve.
3. Remove the top cover.
4. Unplug the "old" filter – disconnect filter from quick connectors (memorise filter orientation).
5. Replace the filter – **Pay attention to correct water flow direction!**

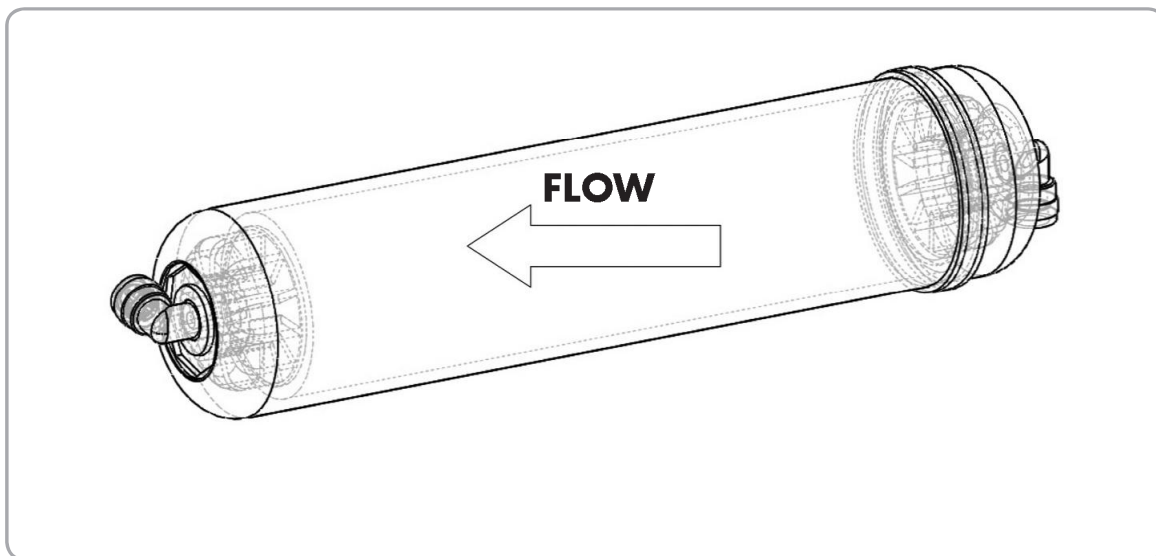

6. Check all connections and make sure there are no water leaks.
7. Close the top cover.
8. Open the inlet water valve and turn on the power supply.





Restoring Leakage sensor:

1. Turn off the power supply
2. Close the inlet water valve
3. Remove the top cover
4. Repair the leakage
5. Drain the water out of the housing by removing the rubber cap at the bottom of the housing.
6. Dry the sensor



Warning!

When installing a new filter, pay special attention to water flow direction – the arrow on the filter label shows the correct water flow direction.

The filter cannot be installed upside down.

PP Filter

PP Filter (5 micron)

Notice:

1. Life time approx. 6months
2. Max flow: 0.75 GPM
3. Max pressure: 125 PSI
4. Max temp. 38 °C
5. Install the filter in the same direction as water flow



Lot:
YYYY - W XY

Item Code:
WT-100-72

Country of Origin:
Made in China



FLOW



No.1

After filter replacement

“Select” button: After the filters are replaced, press the “Select” button to select the corresponding filter icon. Icon will start to blink.

“Reset” button: Select the corresponding filter and press the “Reset” button, hold for more than 3 seconds until the function is effective. After resetting, the red light will turn green.

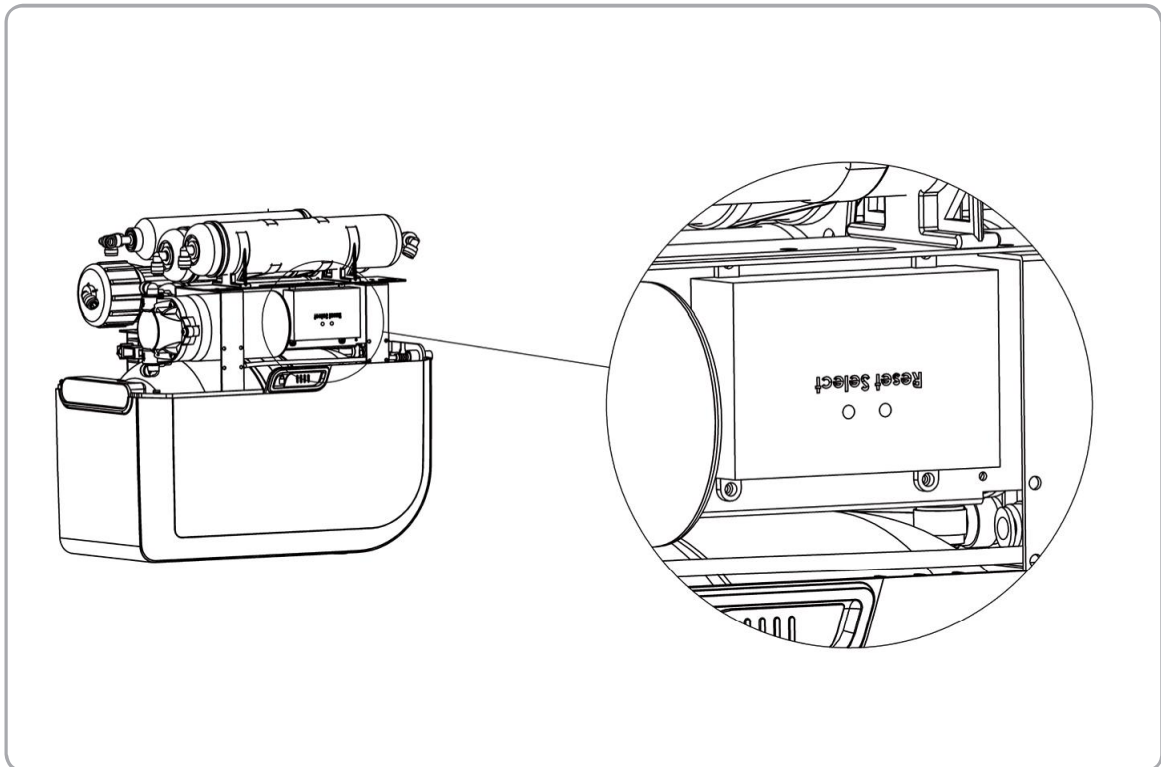

The RO replacement procedure

1. Turn off the power supply.
2. Close the inlet water valve.
3. Remove the top cover.
4. Unplug the "old" filter – disconnect filter from quick connectors
5. Replace the filter – Pay attention to correct water flow direction!

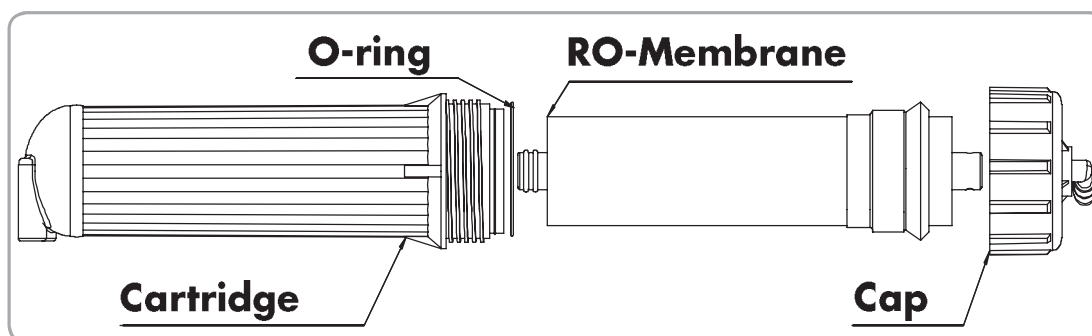

6. Check all connections and make sure there are no water leaks.
7. Close the top cover.
8. Open the inlet water valve and turn on the power supply.

Filter Replacement Time

The AqueenaPro water purifying system is equipped with a special system to monitor filter life time. The system automatically monitors filter conditions and the current status is shown on the **Filter Status Display**.

Green light – the filter works at its optimum level.

Orange light - the filter will soon need replacing. Please contact Zepter Service for maintenance support.

A red light along with an audible alarm (4 buzzes) means that the filter must be changed immediately. Further use of the filter is not recommended.



Attention!

Max. recommended filter replacement cycle represents time equivalent of AqueenaPro engaged in the process of filtration.

Theoretical model used in the calculation of **max. recommended filter replacement cycle** is based on 10L per day of purified water consumption. For demand exceeding the model assumptions, replacement cycle may vary.

The filter replacement cycle is not the filter quality warranty period, but the expected cycle (lifetime) when the filter shows its original performance. The lifetime of the filter is affected by the daily water consumption and inlet water condition, therefore, the filter replacement cycle may be shorter for the areas where the water contains high level of suspended solids (particles, sediments, etc.)

Filter type	Max. recommended filter replacement cycle (months)
WT-100-72 5-micron PP filter	6
WT-100-73 Pellet carbon filter	6
WT-100-74 1-micron PP filter	6
WT-100-75 Coconut filter	12

RO Membrane Replacement Time

Membrane	Max. recommended filter replacement cycle (months)
WT-100-15 RO membrane	12

The manufacturer recommends changing the RO membrane WT-100-15 with the Coconut filter WT-100-75; therefore refer to Coconut filter replacement period as shown on the **Filter Status Display** (No. 5)

Tips!

If you are unsure about the right time for changing your filter,

- Is the TDS level significantly higher than at the beginning of the purification process? (Please refer to your record in the **Warranty Card**).
- Does it take longer to completely fill the water tank compared to the beginning of the purification process?
- Is the amount of waste water greater than at the beginning of the purification process?

If you have answered YES to at least one of these 3 questions, please change your filter(s).

TECHNICAL INFORMATION

EN

PRODUCT NAME:	ZEPTEK AQUEENAPRO
Model	WT-100
Voltage	AC100-240V, 50-60HZ
Power Rating	25W
Size (mm)	408wx265dx420h
Suitable Inlet Water Pressure	0.07-0.75MPa
Operating Pressure	0.6MPa-0.8MPa
Inlet Water Temperature	5-38°C
Maximum Inlet Water TDS Value	< 2000 PPM
Maximum Daily Water Production Volume	100 Gallons, approximately 378.5 Litres
Self-flushing system	YES
Electric Shock Protection Type	Type II
Tank Capacity	9.5 l (usable capacity 6 l) 2.5 Gallons (usable capacity 1.6G)
Suitable Water Quality	Primly designed for municipal tap water.
Country of Origin	China

OPERATING INFORMATION

General Operating Information	Value	Unit
Rated Capacity*	<378	[L/day]
Min-Max Feed Water Pressure	0.69MPa - 0.75MPa 10-110	[MPa] [psi]
Min-Max Feed Water Temperature	5-38	[°C]
Product Recovery Rate**	42	[%]
Maximum Feed Water Hardness	<1000	[mg/L]
Maximum Feed Water TDS	<2000	[ppm]
Maximum Feed Water Dissolved Iron	<2	[mg/L]
Suitable Feed Water pH	6-8	[-]
Turbidity	<3	[NTU]

* at 5 bar feed water pressure and 25° C feed water temperature
 ** at 3.5 bar feed water pressure and 25° C feed water temperature; TDS <750ppm.
 Measured with closed tank

TROUBLESHOOTING GUIDELINE

Failure	Reason	Possible cause
The machine will not start	• Power source not connected	• Check power source or power source plug
	• Low inlet water pressure or no water	• Check inlet water pressure
	• Low-pressure switch failure, cannot connect the power source	• After connecting the inlet water, measure the resistance and replace if needed
	• High-pressure switch cannot be restored	• After easing pressure, measure the resistance and replace if needed
	• Transformer is burned out	• Measure output voltage and replace if needed
The high pressure pump is working properly, but no water is being produced	• High-pressure pump has lost pressure	• Measure water pump pressure and replace if needed
	• Inlet water solenoid valve is faulty, no water can get in (no pure water)	• Replace solenoid valve
	• A pre-filter is clogged	• Check pure water and waste water and replace the pre-filter
	• Non return valve is blocked (waste water, no pure water)	• Replace the non return valve
	• RO Membrane is clogged	• Clean or replace the RO membrane
The storage tank is full but no pure water is flowing out	• Storage tank doesn't have enough pressure	• Inflate the storage vessel and empty tank; pressure should be between 0.05 and 0.07MPa
	• Post-activated carbon filter is clogged	• Replace the post-activated carbon filter
The machine is turned off but waste water has not stopped	• Inlet solenoid valve failed, cannot effectively cut off water supply	• Check waste water, replace the inlet solenoid valve
	• Non return valve has lost pressure (low waste water flow rate)	• Check waste water, replace the non return valve
After the machine is filled with water, the machine starts repeatedly	• Non return valve has lost pressure	• Replace the non return valve
	• High-pressure switch failure	• Replace the high pressure switch
	• Loss of pressure in the system	• After checking the non return valve, check for any water leaks in the pipelines
Pure water flows slowly or is not flowing	• Pre-filter is clogged	• Replace the pre-filter
	• RO membrane is clogged	• Wash or replace the RO membrane
	• Inlet solenoid valve failure	• Replace the inlet solenoid valve
	• Non return valve is clogged	• Replace the non return valve
	• Post-carbon filter is clogged	• Replace the post-carbon filter
	• High-pressure pump pressure is not enough	• Measure high-pressure pump water pressure, replace if needed

DISPOSAL INFORMATION

EN

In accordance with art. 13 of Legislative Decree no. 151 dated 25 July 2005, the implementation of European Directives 2002/95/EC, 2002/96/EC and 2003/108/EC on the reduced use of hazardous substances in electrical and electronic equipment and their disposal, the barred bin symbol means that used electrical and electronic products should not be mixed with general household waste. For proper treatment, recovery and recycling, please take this product to designated collection points at the end of its useful life.



Disposing of this product correctly will help save valuable resources and prevent any potential negative effects on human health and the environment, which could otherwise arise from inappropriate waste handling.

WARRANTY CARD

Product: AqueenaPro, WT-100

Warranty period: months

Serial No.:

Lot No.:

CUSTOMER DETAILS

Customer's name:
Customer's address:
Phone number: e-mail:
Invoice number: Invoice date:

INSTALLATION DETAILS

Name and stamp of installation service provider:
Date of installation:
TDS of raw water: TDS of purified water
Customer signature:
Service technician signature:

SERVICE CONTACT

Name:
Address:
Phone number e-mail:

WARRANTY STATEMENT

EN

All our appliances have been thoroughly tested following strict procedures and are guaranteed against manufacturing defects. The Warranty is valid from the date of purchase, as indicated on the invoice issued by the dealer upon delivery of the appliance. The manufacturer undertakes to repair or replace, free of charge, any parts that are found to be defective within the Warranty period. Defects that are not clearly attributable to either faulty materials or manufacturing processes will be examined at one of our Zepter Service Centres or our headquarters and charged according to the outcome.

The warranty is only valid if:

1. The machine has faulty materials or manufacturing defects.
2. There are no signs of tampering by the customer or original parts having been fitted by unauthorised personnel.
3. Original accessories have been used.
4. The machine has not been overloaded or caused to crash.
5. The device has been maintained in line with the manufacturer' recommendations.
6. All filters and membrane have been changed regularly and the recommended filter replacement period has not been exceeded.

The Warranty does not apply to:

1. Components subject to wear and tear.
2. Damage caused by transport, incorrect use, negligence or faulty installation, as per the warnings set out in the product catalogue.
3. Consumables (including filters and membranes, which have to be replaced regularly).

This Warranty does not affect the consumer's statutory rights applicable under the national legislation in force, or consumers' rights to claim against the retailer as set out in the sales/purchase agreement.

In the absence of applicable national laws, this Warranty will be the consumer's sole and exclusive remedy. In this case, the manufacturer will not be liable for any accidental or consequential damage arising from the breach of any express or implied guarantees of this product. The manufacturer's liability will be limited to and will not exceed the product purchase price paid by the consumer.

This Warranty does not cover damage to the product resulting from abuse or misuse, inappropriate packaging, accidents, or maintenance and repair operations carried out by unauthorised service centres.

The manufacturer reserves the right to withdraw this Warranty if the label containing the product serial number has been removed or rendered illegible after purchase.

AQUEENAPRO PERFORMANCE DATA SHEET

AqueenaPro has been tested by an authorised Drinking Water Laboratory for the substances and conditions shown in the following table.

Substance	Unit	Feed Water	Reduction Rate [%] (effluent drinking water)
Chemical composition			
Field parameters			
Pressure	bar		3.5
Water Temp	°C		25
Feed Water - Sample Volume	L		100
Physiochemical parameters			
	Unit	Feed Water	Reduction Rate [%]
Turbidity	NTU	>1	>85%
pH ¹⁾	pH	7+10%	neutral
Hardness and cations			
	Unit	Feed Water	Reduction Rate [%]
Total hardness ppm	mgCaCO ₃ /L	270±20%	>96%
Calcium (dissolved)	mgCa/L	90±20%	>98%
Magnesium (dissolved)	mgMg/L	20±20%	>86%
Anions			
	Unit	Feed Water	Reduction Rate [%]
Chloride	mgCl/L	40±20%	>97%
Nitrate	mgNO ₃ /L	120±20%	>91%
N- and P- compounds			
	Unit	Feed Water	Reduction Rate [%]
Nitrite	mgNO ₂ /L	0.50±10%	>93%
Ammonium	mgNH ₄ /L	0.1±20%	>80%
Elements and heavy metals			
	Unit	Feed Water	Reduction Rate [%]
Arsenic (V) (dissolved)	mgAs/L	0.5±20%	>99%
Lead (dissolved)	mgPb/L	0.5±20%	>95%
Cadmium (dissolved)	mgCd/L	0.5±20%	>98%
Iron (dissolved)	mgFe/L	0.5±20%	>96%
Manganese (dissolved)	mgMn/L	0.5±20%	>99%
Mercury (dissolved)	mgHg/L	0.5±20%	>98%
Microbiological			
	Unit	Feed Water	Reduction Rate [%]
Total Germs (72h@22°C)	[CFU/ml]	6000-8000	>99.999%
Total Germs (24h@37°C)	[CFU/ml]	4000-6000	>99.999%
E.Coli	[CFU/100ml]	600±20%	Not detectable
Enterococcus	[CFU/100ml]	600±20%	Not detectable

¹⁾Final pH value depends on concentrate of dissolved gaseous fraction of carbon dioxide. High concentrations have tendency to lower pH.

*Tested under laboratory conditions, actual performance may vary